

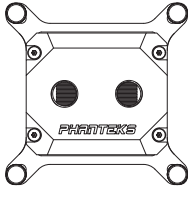

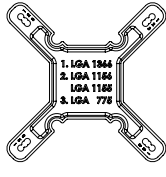
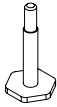

PH-C350ip_BK01

PACKAGE CONTENTS

 <p>C350ip Block</p>	 <p>Backplate</p>	 <p>4x</p>	<p>Socket Screws for:</p> <ul style="list-style-type: none"> - 115x - 1366 - 775 	 <p>4x</p>	<p>Socket Screws for:</p> <ul style="list-style-type: none"> - 2011-3 - 2066
		 <p>4x</p>	<p>Acetal Standoff</p>		
					<p>Thermal Compound (PH-NDC_01)</p>

⚠️ DISCLAIMER - This product is intended for advanced users. Please consult with a qualified technician for installation. Phanteks assumes no liability for any damages occurring as a result of using Phanteks cooling products.

⚠️ WARNING - Power down the system before installation.
 - Do not disassemble the waterblock. Warranty will be voided.
 - Perform a leak test before turning on the system.
 - Check our website for the latest installation guide.

INSTALLATION for socket 115x/1366/775, for socket 2011/2066 see next page.

Socket positions:

Position 1: 1366

Position 2: 115x

Position 3: 775

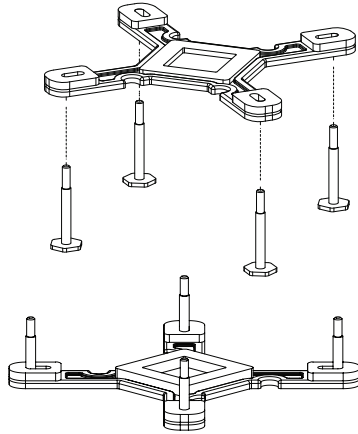
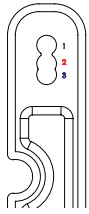
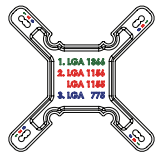

STEP 1. PREPARING THE BACKPLATE

Choose the correct position for the Socket Screws. Insert the four (4) screws into the correct position indicated on the backplate.

⚠️ Please verify that all four screws are inserted correctly:

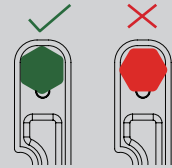

STEP 2. INSTALLING THE BACKPLATE

Place the back plate on the rear side of the motherboard so that the socket screws will stick through the socket mounting holes. Please see image for reference.

⚠️ Make sure the orientation of the backplate is correct:

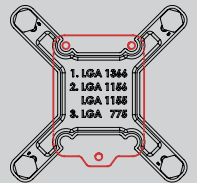

STEP 3. INSTALLING THE ACETAL STANDOFFS

Place the four (4) included Acetal Standoffs onto the socket screws.

STEP 4. APPLYING THERMAL COMPOUND

Make sure the CPU is clean and clear of any residual traces of thermal paste. Apply a dot (4-5mm size) of Phanteks thermal compound on the center of the CPU surface.

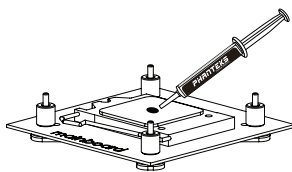

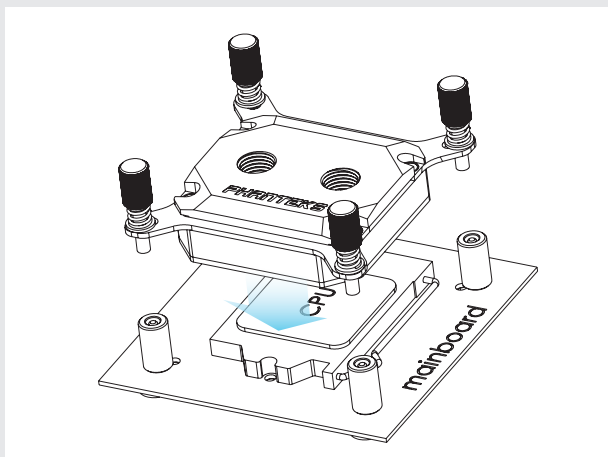

STEP 5. INSTALLING THE C350ip Block

Remove the protective film on the copper base first.
Place the C350ip block on the CPU and tighten the thumb-screws by hand.



Thanks to the C350ip's symmetrical design. Both ports can be used as an inlet or outlet for the water loop.



By securing the screws in a diagonal sequence, the mounting pressure will be distributed evenly. This optimizes the cooling performance.



Do not use force to overturn the thumb-screws. Please stop when the screws are at a natural stop.

INSTALLATION for socket 2011-3/2066

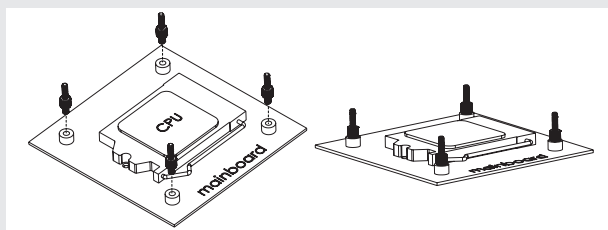

STEP 1. INSTALLING THE SOCKET SCREWS

Place and tighten the four (4) included socket screws by hand on the Intel 2011-3/2066 socket.

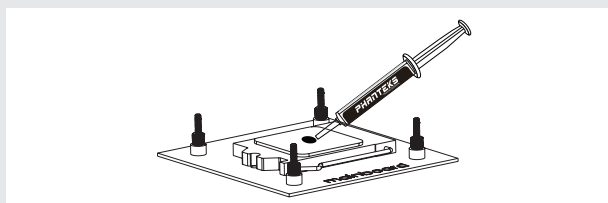

STEP 2. APPLYING THERMAL COMPOUND

Make sure the CPU is clean and clear of any residual traces of thermal paste .
Apply a dot (4-5mm size) of Phanteks thermal compound on the center of the CPU surface.

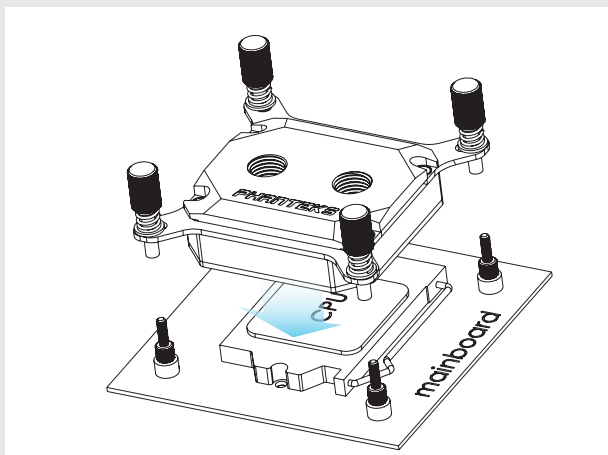

STEP 3. INSTALLING THE C350ip Block

Remove the protective film on the copper base first.
Place the C350ip block on the CPU and tighten the thumb-screws by hand.



Thanks to the C350ip's symmetrical design. Both ports can be used as an inlet or outlet for the water loop.



By securing the screws in a diagonal sequence, the mounting pressure will be distributed evenly. This optimizes the cooling performance.



Do not use force to overturn the thumb-screws. Please stop when the screws are at a natural stop.

FINAL STEP. POWER ON



Please check the following:

- Make sure the block is seated properly on the CPU.
- Always perform a leak test before turning on the system.
- Use paper towels under fittings and joints to avoid damage.
- Make sure all hardware has been tested before starting your water loop.



Let the pump run for multiple hours. Tilting the system can help to release air bubbles.